

Serie F

V16/18
V22
V25
V30

F22
F28

R32
R40
R45

TCS
DIGIT
AUTOMAX

VFRHT

S E R I E



F22
F28



SERRMAC

F22

Bench, column and on pedestal drilling machine

Bench, column and on pedestal drilling machines equipped with variable-speed drive-unit that allows the ideal choice of speed according to the material and to the drilling diameter. The spindle-speed control-level and all the electrical control devices are grouped on the front size of the machine in order to allow an easy utilization.

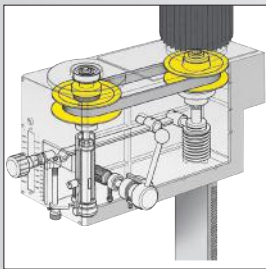

Variable-Speed unit



VARIABLE



PN: 350 x 250 mm
Rectangular table with rack



PG: 350 x 250 mm
Tilting table with rack



PGM: 350 x 250 mm
Tilting table with vice and rack



TC: 475 x 153 mm
Cross table



Bench

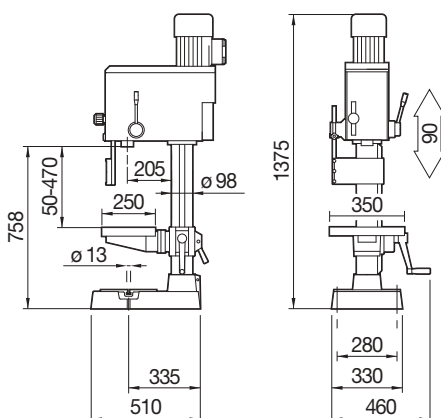

Column

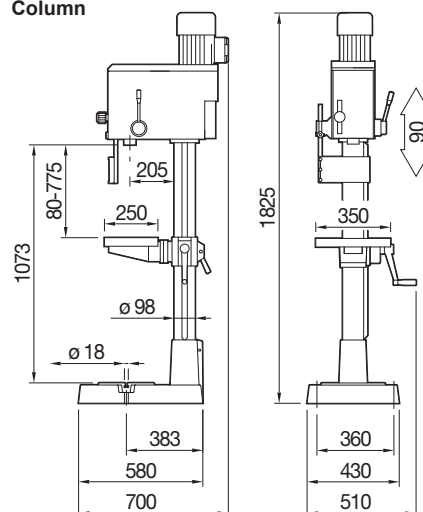

TMF

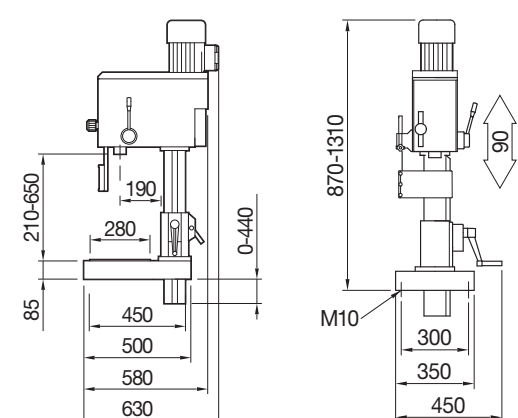

Serie F

F22 – F22B

F28

TECHNICAL DATA		F22 – F22B	F28
Drilling capacity on R50 steel	mm	∅ 22	∅ 28
Tapping capacity on R50 steel	mm	M 14	M 18
Spindle-intake		MT2	MT3
Quill-stroke	mm	90	120
Spindle-quill diameter	mm	52	62
Column diameter	mm	98	98
Transmission		Variable drive unit	Variable drive unit
Spindle speed	rpm	320 – 2.680	250 – 2.150
Motor Power (380 V – 50 Hz)	kW	0.75	1.1
T-slots dimensions and interaxis	mm	N° 2 / 12 / 100	N° 2 / 12 / 100
Cross Tabel - travels	mm	280 X 160 (Column)	280 X 160
T-slots dimensions and interaxis for TC	mm	N° 2 / 16 / 60	N° 2 / 16 / 60
Bench model dimensions (h x w x d)	mm	1.310 x 450 x 630	–
Column model dimensions (h x w x d)	mm	1.825 x 510 x 700	1.885 x 510 x 700
Weight	Kg	188 (Column) – 128 (Bench) – 160 (Pedestal)	195 (Column) – 170 (Pedestal)

* F22 - F22B option: motor 0.6/0.9 kW – 160/2.680 rpm * F28 option: motor 0.6/0.9 kW – 125/2.150 rpm



Code 40022: 24 V LED light.



Code 18020: Cooling system.



Code 18080: Thread-cutting unit.



Code 40024: Digital speed counter.



Code 16003: TMF pedestal.

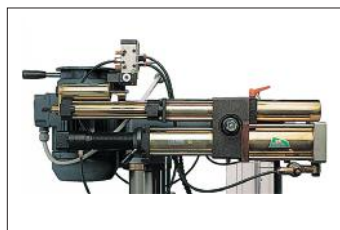

Code 30019: Hydropneumatic feed.

UR80 Automatic spindle quill-stroke
90 mm with adjustable rapid
release feeds.
Feed 5÷2.500 mm/min.
Thrust power 6 bar: 400 Kg.

SERRMAC

SERRMAC INTERNATIONAL S.r.l.

Via delle Industrie, 9 • 33070 POLCENIGO (PN) - Italy

Tel. +39 0434 671021 • Fax +39 0434 671031

info@serrmac.it • www.serrmac.it

Official dealer



The Company SERRMAC has the right to make the needed modifications without any notice